



CALIFORNIA DYNAMICS CORPORATION
 5572 ALHAMBRA AVE.
 LOS ANGELES, CA. 90032-3106

CALL US - TO SET THINGS RIGHT

FAX (323) 223 - 7941

PH (323) 223 - 3882

email: caldyn@earthlink.net

TYPE VT
 MOUNTING PAD
 WITH GAGE METAL
 STEEL PLATE

FILE 240

3/24/00

JOB: _____

CUST: _____

ENG'R: _____

TAG: _____

DATE: _____

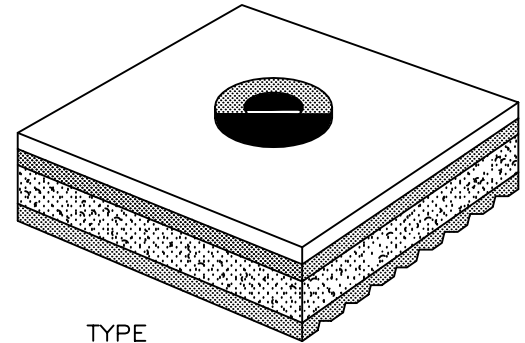

TYPE VT
 MOUNTING PAD

Isolator Selection & Loc.

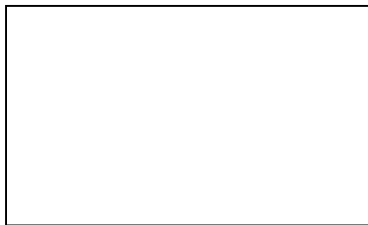

TYPE	(MOUNT No.) Max. Load (lbs.)	DIMENSIONS (Inches)				SHIP Wt. (lbs.)
		Length	Width	Thickness	Gage No.	
VT	200	2	2	1-1/8	7	.5
VT	300	2-1/2	2-1/2	1-1/8	7	.5
VT	450	3	3	1-3/16	11	.75
VT	800	4	4	1-3/16	11	1.75
VT	1200	6	4	1-3/16	11	2.25
VT	1800	9	4	1-3/16	11	3.10
VT	2400	12	4	1-3/16	11	4.60

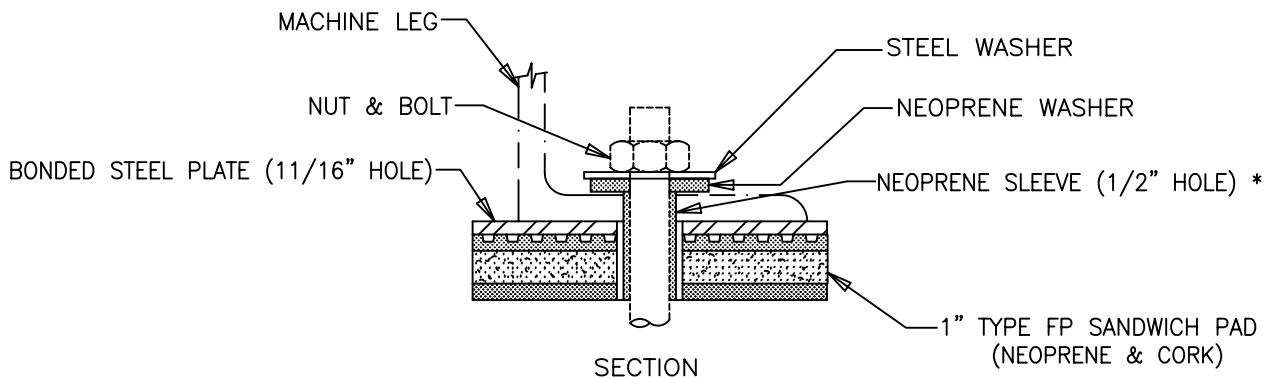

TYPICAL CALLOUT

QUANTITY _____ SIZE (MAX. LOAD) _____
 TYPE _____
 4 - VT - 450

* LARGER SIZE HOLES AVAILABLE ON REQUEST.